

NVFB-LD

Non Ventilated Fire Barrier - Low Density

Tenmat's NVFB-LD (low density non-ventilated fire barrier) is a highly compressible cavity barrier designed to maintain fire resistance performance within external wall cavities.

Product Description

Tenmat's Non-Ventilated Fire Barrier (NVFB-LD) is a full fill cavity fire barrier manufactured from a Euroclass A1 Reaction to Fire classified 100mm thick low density stone wool.

The product is installed between the inner and outer substrates of a masonry façade to reinstate the fire resistance performance of the cavity. The lighter density allows greater scope for compression when installing within brickwork cavities when using wet mortar.

The Tenmat NVFB-LD has been tested to EN1366-4:2021 and can provide up to 120 minutes integrity and 60 minutes insulation fire resistance performance (please see the tables on page 3 for the full fire resistance performance based on cavity widths and orientation).

Intended Use

Tenmat's NVFB-LD is designed and tested for installation within masonry cavities up to 300mm wide to reinstate the fire resistance performance of the cavity.

The lower density design allows the 5mm compression requirement to be more easily achieved. This results in greatly reduced risk of pushing out bricks when installing in masonry cavities using wet mortar. This can in turn significantly speed up installation and progress on site.

For fire test data and the tested applications please review the performance tables in this data sheet.

Please contact Tenmat with any further questions on suitability of the product for specific applications.

Product Details

- CCPI Verified
- Fire Tested to EN1366-4 : 2021
- A1 Reaction to Fire
- Low density design
- Allows ease of compression when installing in cavities with wet mortar
- Only 5mm compression required
- Suitable for masonry cavities up to 300mm
- Tested both vertically and horizontally
- Supplied as plain mineral fibre as standard
- Provided in 1.2 metre lengths
- Standard thickness of 100mm
- No maintenance required after installation

Sizes

Cut to Size: 100mm deep/thick x width to suit cavity (+5mm for compression fit x 1200mm long

Full Slabs: 100mm x 600mm x 1200mm

Approved Applications

Non-Ventilated Cavity Fire Barriers for external wall cavities

Fire Test Evidence

Inner Leaf Substrate Type (facing cavity) with appropriate fire resistance	Outer Leaf Substrate Type (facing cavity) with appropriate fire resistance	Orientation	To suit cavity widths (in mm)	Compression required	Minimum Thickness of NVFB-LD (mm)	Product Fire Resistance Rating	
						Integrity	Insulation
Rigid Walls - min. 100mm thick							
100mm Masonry or Concrete walls	100mm Masonry or Concrete walls	Vertical	10-100	5mm	100	120	60
100mm Masonry or Concrete walls	100mm Masonry or Concrete walls	Vertical	101-300	5mm	100	60	15
SFS System Walls							
SFS System Walls ¹	100mm Masonry or Concrete Walls	Vertical	10-300	5mm	100	60	15
Rigid Floors - min. 150mm thick							
150mm Masonry or Concrete Floors	150mm Masonry or Concrete Floors	Horizontal	10-100	5mm	100	120	15
150mm Masonry or Concrete Floors	150mm Masonry or Concrete Floors	Horizontal	101-300	5mm	100	60	15

Rigid floors: Minimum 150mm thick and comprised of concrete, aerated concrete or masonry, with a minimum density of 650kg/m³.

Rigid walls: Minimum 100mm thick and comprised of concrete, aerated concrete or masonry, with a minimum density of 650kg/m³.

The supporting construction must be classified in accordance with EN13501-2 for the required fire resistance period.

¹ SFS System build up - 115mm overall thickness comprising, 90mm and 94mm Metsec steel profiles and 100mm Rockwool 45kg/m³ insulation, clad internally with 1 x 12.5mm plasterboard, clad externally with 1 x 12.5mm Siniat Weather Defence gypsum based board, outer substrate 100mm thick aerated concrete blocks.

Fire test evidence, safety data sheets and previous versions of product information are all available upon request by contacting Tenmat, please [click here](#)

Technical Information

Material	Stonewool
Finish	Plain
Storage	Dry, ambient (see Safety Data Sheet)
Weight	Bespoke sizes ranging from 0.05kg to 5.5kg dependent on size to suit cavity width.
Thermal Conductivity - EN 13162	$\lambda_D = 0.035 \text{ W/mK}$
Reaction to Fire	Classified 'A1' to EN13501-1
Resistance to Fire	See Fire Test Evidence table
Durability of reaction to fire and thermal conductivity to EN 13162 (stone wool element)	Reaction to fire and thermal conductivity does not change with time against heat, weathering, ageing/degradation.

The product is not subject to any warning or ban under Section 26 of the NZ Building Act 2004.

Fire Barrier Support Details

Cavity Size (mm)	Product Width (mm) including 5mm compression	Orientation	Fitting Option Number	Barrier Support Type	No. of brackets / fixings per 1.2m length	Maximum Bracket Centres (mm)	Face Fixed Fixing Centres (mm)
10-75	15-80	Vertical or Horizontal	1	Screw	3	N/A	450
76-300	81-305	Vertical or Horizontal	2	MP Bracket	3	450	N/A

Pre Specification

The principal designer must approve the use of any cavity barrier, whether open state or full fill, in conjunction with the products fire test evidence, taking full account of the whole construction of the external wall systems and components, including any requirements of Building Regulations and/or NHBC Standards.

Before a Tenmat NVFB-LD cavity barrier is recommended by Tenmat, the following information is required to ensure that the suggested product is considered suitable for the intended application by Tenmat, within the construction as indicated by the client.

- 1) Project name, location and postcode.
- 2) Building height and use (as per ADB V1/2 2020).
- 3) Fire resistance period/rating required. Integrity and Insulation (EI).
- 4) Composition and construction of external walls, both inner and outer substrates.
- 5) Total external wall cavity size. (Maximum distance from outer face of inner substrate to inner face of inner substrate including tolerances/profiles).
- 6) Type and thickness of cavity insulation if present.
- 7) What ventilation gap is required horizontally? (Note: NVFB/NVFB-LD does not maintain a ventilation gap, if this is required then a Tenmat VFB / Open State Cavity Barrier should be considered)
- 8) Are non-vented cavity barriers required vertically and horizontally?
- 9) Quantity required to complete project?
- 10) When will materials be required?
- 11) Name and role of person completing form.

When the above information is obtained then this can be cross referenced with the full range of Tenmat cavity barriers to ensure that the product recommended, by Tenmat, is considered suitable for consideration by the principal designer.

Installation Considerations

NVFB-LD cavity barriers would typically be installed in a continuous run. Where this is not possible, details should be agreed with the projects principal designer and or fire engineer.

Horizontal cavity barriers would generally be installed adjacent and tightly abutted to any vertical cavity barriers, the vertical NVFB-LD cavity barriers would normally be installed first. NVFB-LD cavity barriers may be cut to length as required, adjacent lengths must be tightly abutted together.

The principal designer must sanction any untested interruptions, which may include items such as brackets, rails or battens, that may affect the continuous line of the cavity barrier. The principal designer must consider the combustibility, melting points and the shape of any interruptions, that are likely to prevent the cavity barrier performing as tested or as expected in the projects design.

If there are interruptions / obstructions that prevent the cavity barrier being fitted in a continuous line, and with sanction from the principal designer, the product may be cut tightly butted up against any obstructions and then restarted on the opposite side of the obstruction, the obstruction must not create a void which is not filled.

The cavity barrier should not be penetrated by any mechanical or electrical services other than the mechanical fixings which are used to fix the cavity barrier to the building, unless a non standard detail is agreed with the projects principal designer and or fire engineer.

Cavity barrier fixing brackets must not penetrate through the face of the cavity barrier. Screws for direct fixing and fixings to secure brackets are not supplied by Tenmat.

The use of tape is not required over the joints between the lengths of NVFB-LD.

The Tenmat technical team should be consulted in any instance where the principal designer is uncertain as to any issues which may impede the ability of the cavity barrier to perform as expected.

Ensure the installation area is free from dust, oil and any corrosive material.

The cavity barrier should be installed onto a flat surface, with no gaps behind the cavity barrier. Check the mounting substrate is solid and free from cracks and degradation before beginning.

Installation Instructions

Option 1

NVFB-LD - Vertical and Horizontal
Product widths up to 80mm wide, directly faced fixed.

Position the first screw fixing through the centre line of the face of the cavity barrier at a maximum 150mm from one end, continue to face fix through at maximum 450mm centres (3 screws per 1.2 metre length), ensuring that the final fixing is a maximum 150mm from the end of the cavity barrier.

This will ensure that face fixings are positioned at 450mm centres across the continuous run of cavity barrier.

Use stainless steel screws, with a maximum head diameter of 16mm and with a length suitable for the cavity barrier and the substrate.

Ensure that the screw head fully penetrates the face of the cavity barrier, the screw head should sit at least 5mm behind the face of the cavity barrier. Care should be taken not to compress the surface more than 10mm as this may affect the performance of the cavity barrier.

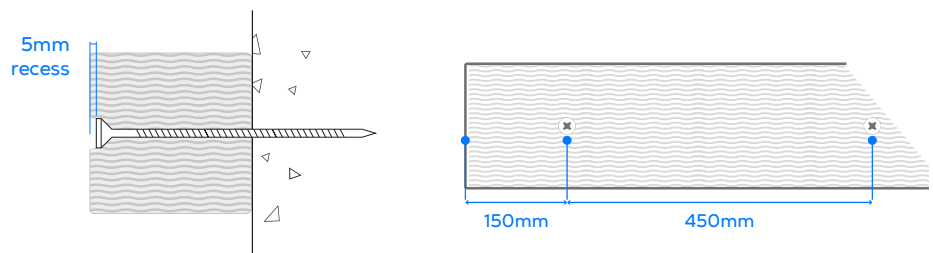

Fixing Detail for Shorter Lengths

Where sections of cavity barrier are less than 1.2 metres in length, ensure that face fixings are positioned at a maximum 150mm from each end. For cut sections of cavity barrier less than or equal to 300mm in length only one fixing is required. For cut sections 301 to 500mm then 2 fixings should be used distanced equally from each end.

Option 2

NVFB-LD - Vertical and Horizontal

Product widths from 81mm up to 305mm wide, fixed using 3 Multi Purpose (MP) 160mm brackets.

Note:

If cutting the NVFB-LD to size from a full slab for the above sizes, care should be taken to ensure cut dimension allows for the minimum compression to be achieved and that the cut edges are square. To ensure a square cut, the use of a cutting station/bench for accurate cutting could be considered.

After cutting, all other instructions and fixings details below should be followed.

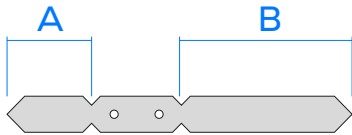

MP brackets are supplied with 2 fixing spikes, one spike is 65mm long (A), the other is 160mm long (B), with a central section for securing the bracket to the substrate. The compression allowed for is 5mm, care should be taken to ensure that the end of the bracket will not come into contact with the outer substrate when compression is applied to the NVFB-LD.

For cavity barriers 81mm-95mm wide (across cavity) use 3 MP brackets and the 65mm long spike (A).

For cavity barriers 96mm-305mm wide (across cavity) use 3 MP brackets and the 160mm long spike (B).

The 160mm spike will require cutting to size if used in barriers less than 175mm wide.

To ensure that the spike does not pierce through the face of the cavity barrier, the bracket can be cut to provide a minimum projection through the barrier to 3/4 of the cavity barrier width and to a maximum of 25mm behind the face of the cavity barrier.

For cavity barriers greater than 175mm wide, the MP bracket 160mm long spike (B) is tested and approved and of sufficient length for all NVFB-LD sizes up to the max. 305mm

To secure the bracket use 5mm Ø stainless steel screws, with a maximum head diameter of 13mm and with a length and type suitable for the substrate. Ensure that the screw head sits as flush as possible with the substrate so that the NVFB-LD sits tight against the substrate leaving no gaps. Minimum one screw required per bracket.

If using only one fixing per bracket it must be ensured that the bracket is not at risk of rotating (e.g. for horizontally fixed brackets) and the substrate can accommodate one fixing, if in doubt two fixings should be used.

To secure the bracket use 5mm Ø stainless steel screws, with a maximum head diameter of 13mm and with a length and type suitable for the substrate.

Ensure that the screw head sits as flush as possible with the substrate so that the NVFB-LD sits tight against the substrate leaving no gaps.

Minimum one screw required per bracket.

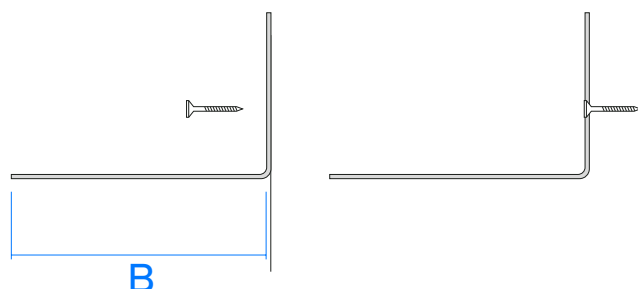

Option 2 (continued)

Fix 3 number MP brackets, per 1.2 metre length, to the substrate at maximum 150mm from the end of the cavity barrier, with a maximum spacing between brackets of 450mm.

Where sections of cavity barrier are less than 1.2 metres in length, ensure that MP Brackets are positioned at a maximum 150mm from each end.

For cut sections of cavity barrier less than or equal to 300mm in length only one bracket is required.

For cut sections 301 to 500mm then 2 brackets should be used distanced equally from each end.

Note: If installing vertical brackets with vertically oriented NVFB-LD, prior to the insertion of the bracket, an incision must be pre-made into the stonewool to the depth of the bracket to prevent damage to the stonewool fibres.

Vertical Install - Brackets may be installed in either orientation

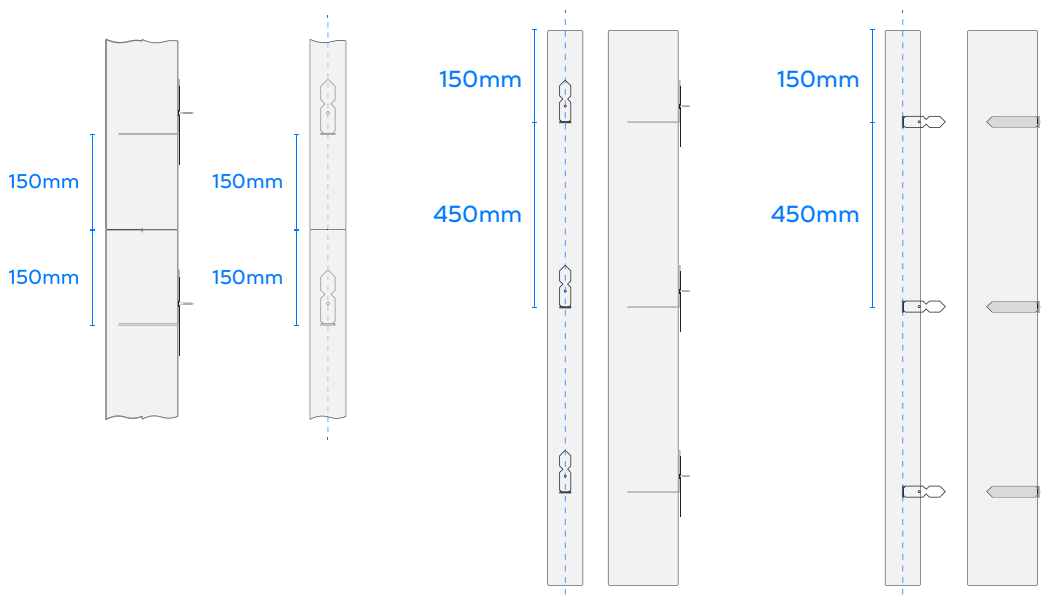

Horizontal Install - Brackets should be installed in below orientation

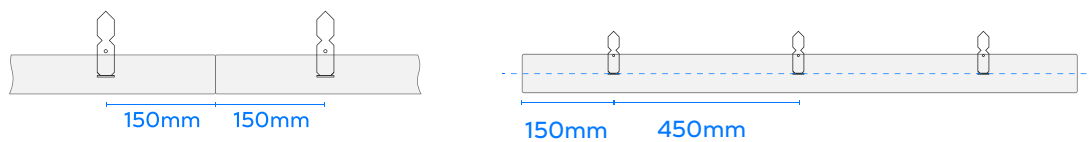

Option 2 (continued)

Push the cavity barrier onto the bracket spike, the brackets should impale the NVFB-LD to approximately mid barrier depth and must not protrude through the face of the cavity barrier, remembering to allow for the final compression against the outer substrate also. The cavity barrier should be pushed fully onto the bracket spike and sit flush with the substrate at the rear of the cavity barrier, ensuring that there are no gaps behind the cavity barrier.

Note: If installing vertical brackets with vertically oriented NVFB, prior to the insertion of the bracket, an incision must be pre-made into the stonewool to the depth of the bracket to prevent damage to the stonewool fibres.

Vertical Install
(vertical brackets)

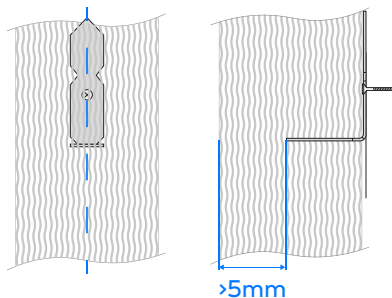

Vertical Install
(horizontal brackets)

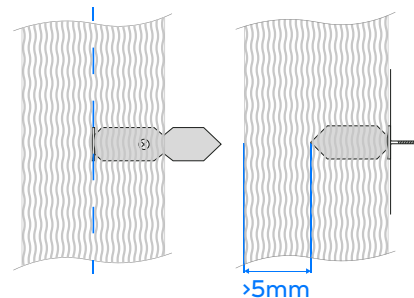

Horizontal Install
(vertical brackets)

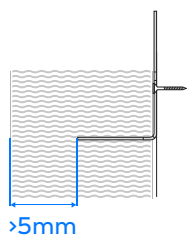

Horizontal Install
(horizontal brackets - check with Tenmat before using this installation method)

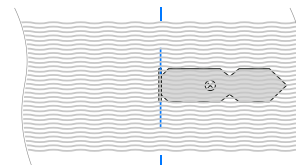
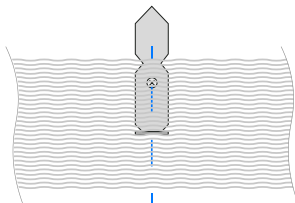

Limitations

To ensure compliance to the relevant test evidence detailed within this Data Sheet, the product must be installed as per the fitting instructions by competent installers. The product must only be used in vertical or horizontal orientations.

Maintenance

- No active maintenance required.
- Where alterations are made around the product it should be checked visually to ensure that the product is still installed as per the approved original design and fitting instructions at the time of original installation.
- Where product(s) is damaged or tampered, new product should be installed in line with installation guidance.

Storage Conditions

- See Safety Data Sheet

Tools Required

- Sharp Knife
- Measuring Tape
- Appropriate drill
- Stainless steel fixings

PPE Required

- Hand protection
- Eye protection
- Follow project site requirements

Disposal

- Foil facing can be cleaned and recycled.
- Stone wool insulation is non hazardous waste and is categorised as “waste accepted at landfill for nonhazardous waste” and local regulations should be followed.

Please see Safety Data Sheet for more information.

NVFB-LD

Tenmat Ltd.
Northbanks Industrial Park,
Irlam, Frank Perkins Way,
Greater Manchester,
M44 5EW

+44 161 872 2181
fpsales@tenmat.com

tenmat.com



Innovate today.
Protect tomorrow.
tenmat.com

Tenmat warrants the materials it produces will conform to Tenmat specifications and approved drawings where applicable. It is entirely the customer's responsibility to make the final product choice and satisfy themselves of the suitability of the product for the intended application, carrying out testing where required. For construction projects, all products which the customer is intending to use on a particular project must be approved in writing by the customer's building designer, system designer or design control professional, to ensure compliance with the latest regulations.

The information contained in Tenmat data sheets is presented in good faith. Tenmat Limited makes passive fire protection product suggestions based solely upon and limited to the information made available to Tenmat. Tenmat possesses knowledge of fire test data and offers manufacturers installation advice. Within reason, Tenmat is skilled at offering opinion concerning the installations in question, and can comment on interfaces with other construction materials, but this is not a recommendation or decision. Decisions on overall building fire strategy are not made by Tenmat. Tenmat products have been tested for a wide range of construction types, and they must be only used in accordance with Tenmat test evidence. Each specific Tenmat product must be installed into a construction that matches the corresponding test report. Tenmat product performance requires safe and proper handling and correct installation.

Doc Reference: TDS-35		
Revision: 3		Date: 24/03/2026
PB: CM	CB: CT	AB: DR